

# HISPANUS

## GENERADOR ELÉCTRICO GUARDIAN ATS SOL 5000W



4-STROKE  
ENGINE



FUEL TANK  
CAPACITY



CLEAN  
ELECTRICITY

# GUARDIAN ATS SOL 5000

## GENERADORES ELÉCTRICOS

### ELECTRIC GENERATORS



## DETALLES / DETAILS

Arranque eléctrico "PUSH IN", arranque su generador simplemente pulsando un botón.

- Sistema ATS/SOL con arranque y paro automático por contacto para instalaciones fotovoltaicas.
- Sistema ATS/SOL con arranque y paro automático cuando nuestro generador detecta cortes de corriente en la Red eléctrica.
- Incluye caja de conexiones con panel indicativo de avería, errores o problemas en el generador.
- Como opción, este modelo puede incorporar arranque a distancia con MANDO RC.
- Sistema STOP UP con parada automática por falta de aceite, activación automática en caso de bajo nivel de aceite.
- Chasis reforzado de 40mm con doble refuerzo, pintura en caliente anticorrosión y conjunto de silent-block acoplados al motor para evitar vibraciones constantes del conjunto.
- Alternador 100% bobinado en cobre, garantiza un funcionamiento perfecto y estabiliza la corriente de manera más precisa, alargando la vida del mismo.
- Regulador electrónico interno, evita alteraciones de corriente AVR.
- Kit de transporte extremadamente robusto para transportar la máquina, incluye ruedas anti-pinchazos macizas de 12".

"PUSH IN" electrical starter. Start your generator by simply pressing one button. Also available with RADIO CONTROL start up to 50m away.

- ATS/SOL system with automatic contact start and stop for photovoltaic systems.
- ATS/SOL system with automatic start and stop when the generator detects power cuts in the main net.
- Includes connection box with panel indicating faults, errors or problems in the generator.
- As an option, this model can include remote start with RC control.
- STOP UP system with automatic stop in case of lack of oil and automatic activation in case of low oil level
- 40 mm reinforced chassis with double reinforcement, anti-corrosion hot painted and silent-blocks set coupled to the engine to avoid permanent vibrations.
- 100% copper-wound alternator that guarantees perfect operation and stabilises the current in a more precise way, extending the life of the alternator.
- Internal electronic regulator that avoids AVR current alterations.
- Extremely sturdy transport kit for transporting the generator. Includes 12" robust anti-puncture wheels.

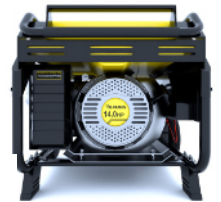
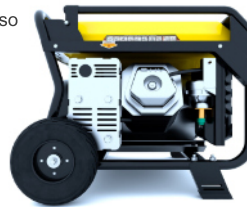
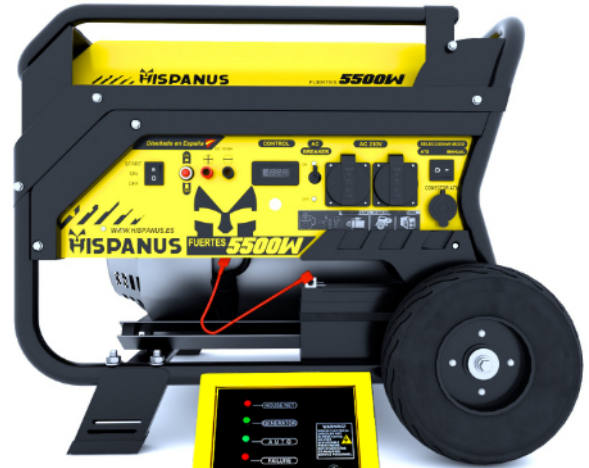

## PANEL DE CONTROL / CONTROL PANEL

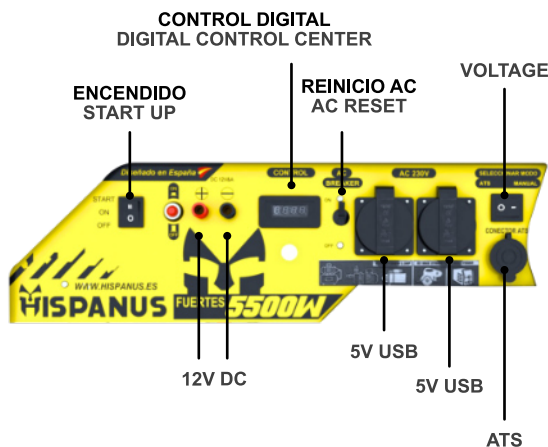

## ESPECIFICACIONES / SPECIFICATIONS

MODELO	MODEL	FUERTES 5000 W	
Voltaje / Frecuencia	Voltage / Frequency	230V – 50Hz	230V – 50Hz
AC 230V Máxima	Max. AC 230V	5500W	5500W
AC 230V Continua	AC 230V DC	5000W	5000W
Modelo motor	Motor Model	Hispanus HS14HP	Hispanus HS14HP
Tipo motor	Motor Type	Gasolina, 4 tiempos OHV	Gasoline, 4 strokes OHV
Sonoridad a 7m	Sound Level at 7m	68dB / 75 dB	68 dB / 75 dB
Tipo de arranque	Start Type	Manual-electric-ATS-option RC	Manual-electric-ATS-option RC
Capacidad combustible	Fuel Tank Capacity	25L	25 L
Consumo Autonomía	Fuel Consumption / Run Time	15h – 50% carga	15h – 50% charged
Capacidad / tipo aceite	Oil Capacity / Oil Type	SAE10W30 SAE10W40	SAE10W30 SAE10W40
Kit de transporte	Transport Kit	Sí	Yes
Dimensiones / Peso	Dimensions / Weight	81 x 57 x 56 CM / 95 Kg	81 x 57 x 56 cm / 95 Kg
QTY 20" / 40"	QTY 20" / 40"	212 / 232	212 / 232
Sistema RC	RC System	Si	Yes
Certificados	Certificates	CE / NOISE / EC - V / EPA / CARB / EMC	CE / NOISE / EC-V / CARB / EMC

TIPO DE ARRANQUE Automático

Start Type: Automatic

¿CUANTA POTENCIA NECESITAS?  
HOW MUCH POWER DO YOU NEED?